

VERTICAL DOORS, INC.

VerticalDoors.com

542 3rd St Lake Elsinore Ca 92530
T 951.245.8669 F 951.245.5481



U.S. PATENTS

#6,808,223; #6,845,547; #7,140,075; #7,059,655

PATENTS AGGRESSIVELY ENFORCED!







**PLEASE CAREFULLY READ ALL INSTRUCTIONS BEFORE
ATTEMPTING TO INSTALL THIS PRODUCT.**

**FOR QUESTIONS PLEASE
CONTACT US AT (951) 245-8669**

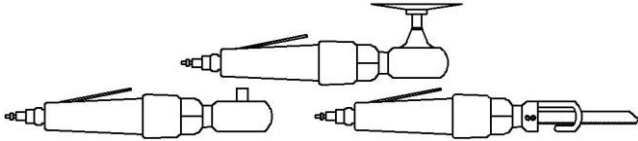
THIS KIT INCLUDES:

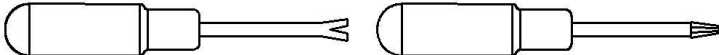
- 12 M8-1.25X30MM
- 08 M8-1.25X50MM
- 12 M8-1.25X40 F.H.C.S.
- RIGHT AND LEFT HINGE ASSEMBLY
- 2 SHOCKS 720L PSI

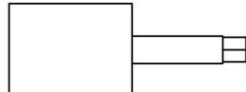
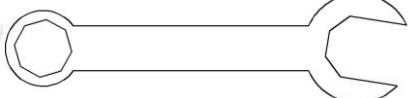
TOOLS REQUIRED FOR INSTALLATION:

	<ul style="list-style-type: none"> ➤ AIR RACHET, GRINDER AND CUTTER.
	<ul style="list-style-type: none"> ➤ 7MM, 8MM, 10MM, 11MM, 13MM, SOCKETS AND EXTENSION.
	<ul style="list-style-type: none"> ➤ FORK AND PHILLIP'S SCREW DRIVERS
	<ul style="list-style-type: none"> ➤ SPACERS FOR THE DOOR GAP.
	<ul style="list-style-type: none"> ➤ 3/16 ALLEN WRENCH
	<ul style="list-style-type: none"> ➤ 1/4 TORX BIT
	<ul style="list-style-type: none"> ➤ 9/16 WRENCH
	<ul style="list-style-type: none"> ➤ LOCKTITE RED

OTHER TOOLS MAY BE NEEDED DEPENDING ON YOUR VEHICLE.

“Installers with experience recommended”

(Note: The pictures on the manual are for reference only they may not match your vehicle.)

1) Disconnect the battery.

2) To install the VDI kit without removing the front end you will need to:

Use painters tape to protect all edges of the door fender and any part of the body that could be scratch during the installation.

Use painters tape to mark the factory location of your door.

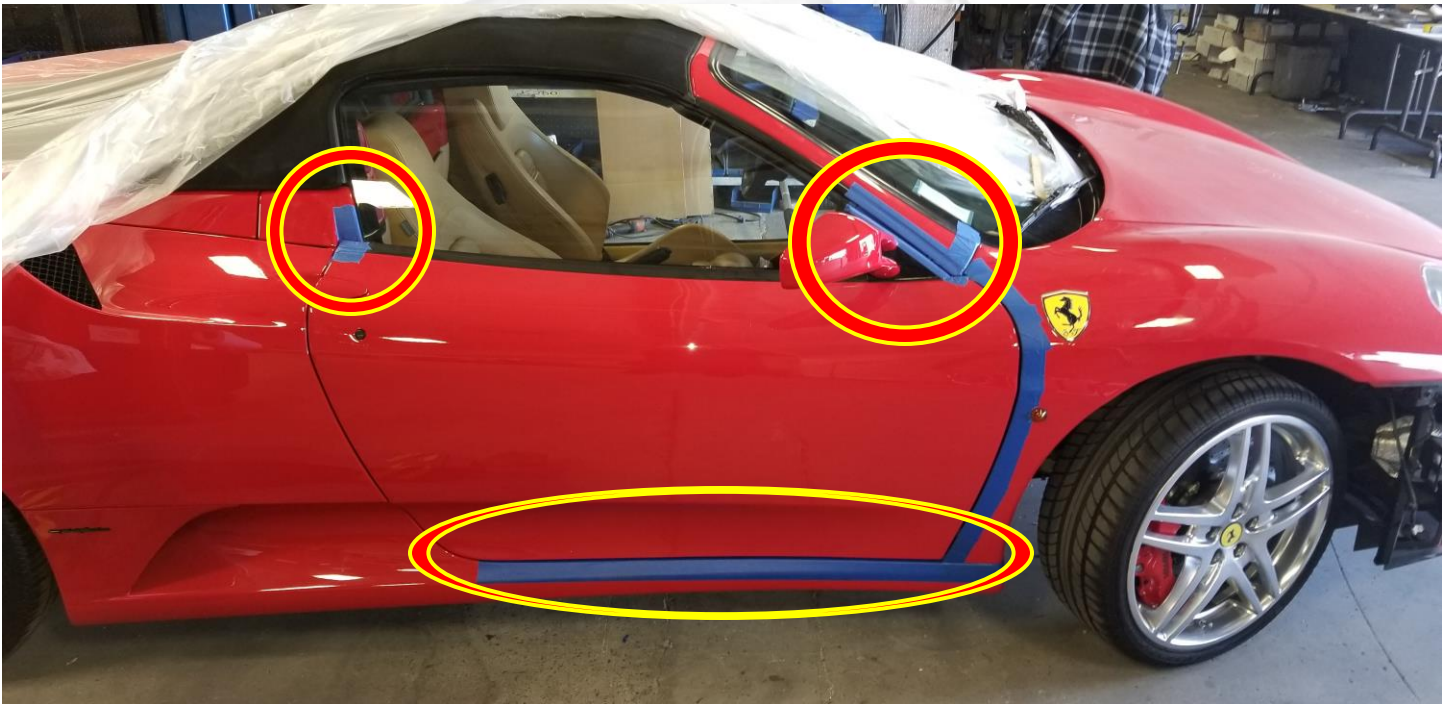

Remove the door by opening the door removing the door catch disconnecting the factory wire harness and removing the factory hinges.

You will need 3 people. 2 holding the door and 1 removing the bolts from the door.



Once the door has been removed you will need to remove the factory spacers from the door as shown.

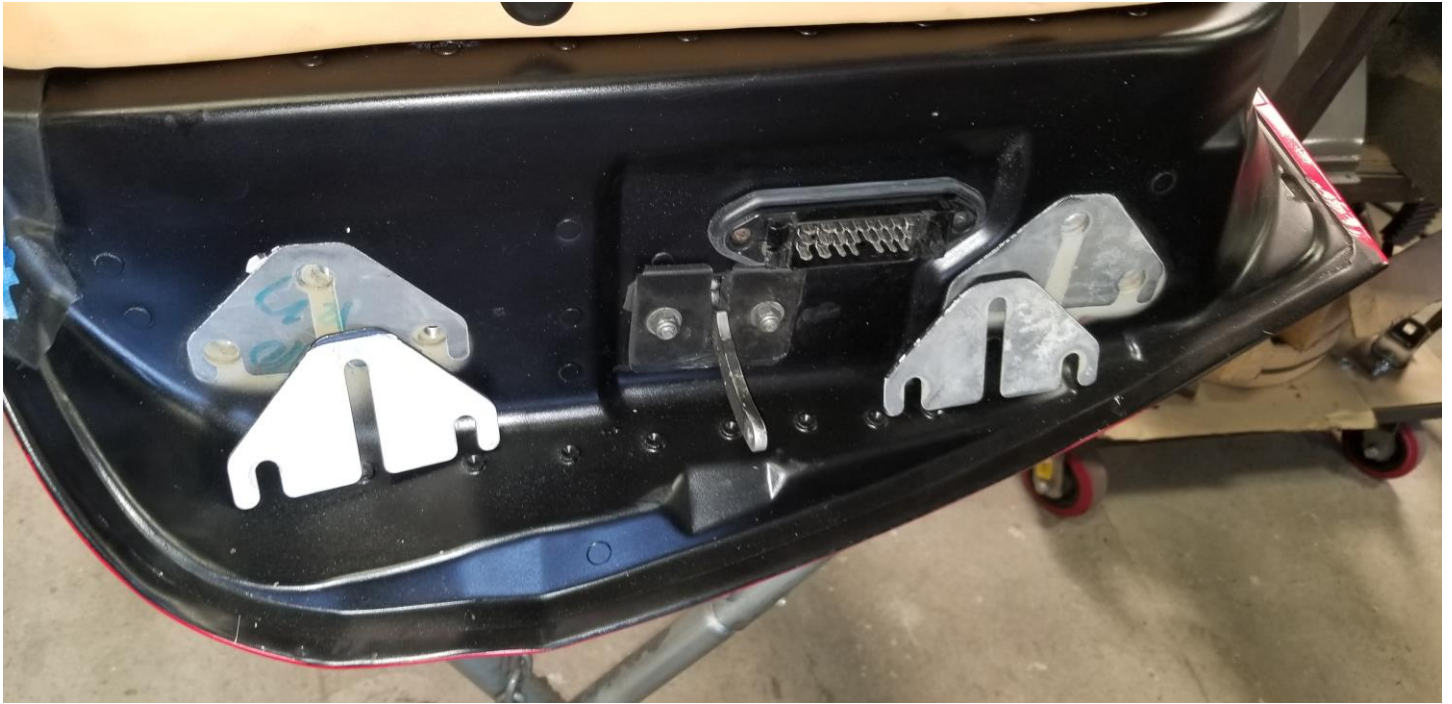

Once the door has been safely removed you will have to remove the door catch as shown.



Once you remove the factory hinge you will have to paint the spot where you took off the hinge to protect it from rust.



After removing the factory hinge you will have to installed the provided spacers. One spacer for the bottom and one for the top.

You will have to remove the wheel and the fender splash guard.

Cut the inner fender to make room for the new VDI kit. Cut the inner fender as shown on the picture on the right.

Just cut enough to allow the VDI hinge to work freely.



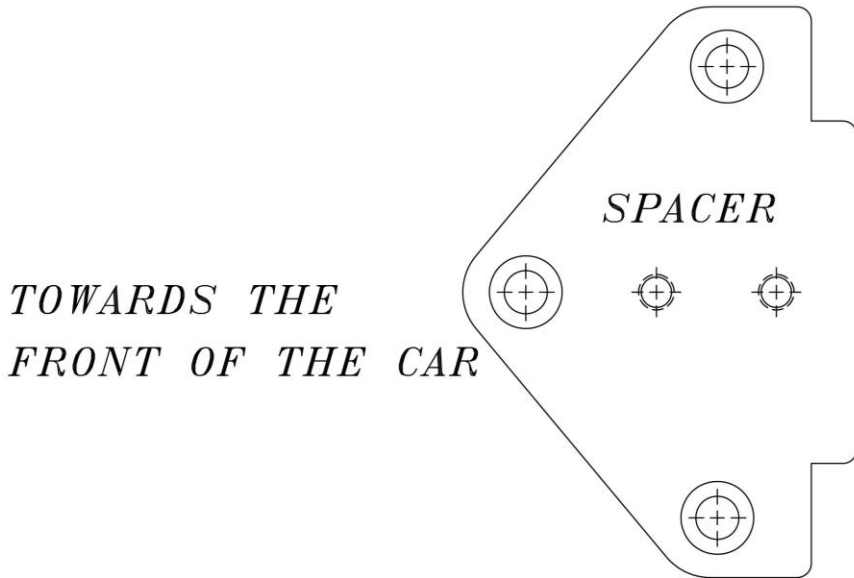
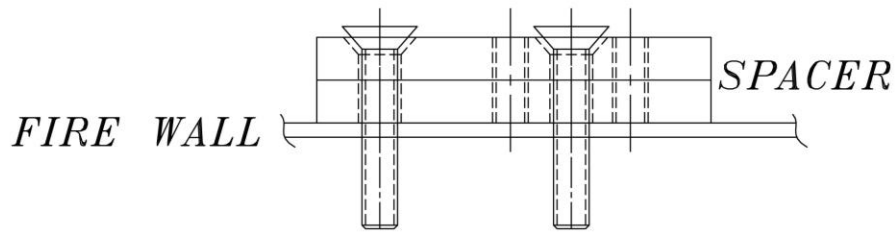

You will have to install the new VDI hinge to the spacers. Once the hinge is installed on the body of the car you will need two people to put the door up to the body and one person securing the 30MM bolts to the door.

After installing the door, carefully lower and close the door, fine adjustment will be needed to make the door close properly.





WARNING! THE USE OF ANY TYPE PLYERS, PAINT OR FOREING MATERIALS ON THE SHOCK'S BODY OR SHAFT WILL VOID THE WARRANTY.

ADD GREASE TO ZERK FITTINGS

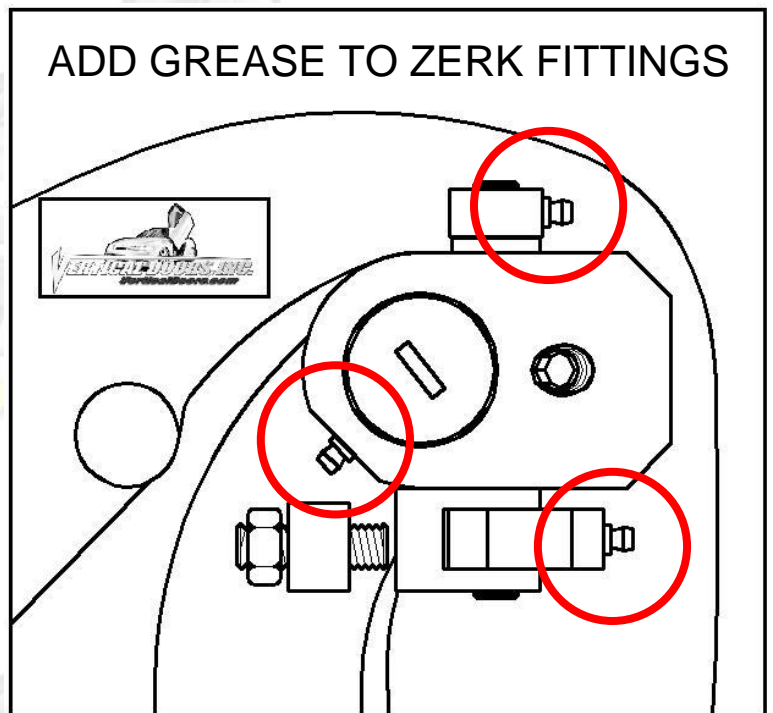

Make sure to grease all Zerk Fittings.

Once hinge is locked in place, break nut #1 then turn Allen set screw #2 on fig until it hits the block then open the door and continue to adjust until the door matches with the striker, open and close door making sure it closes like factory.

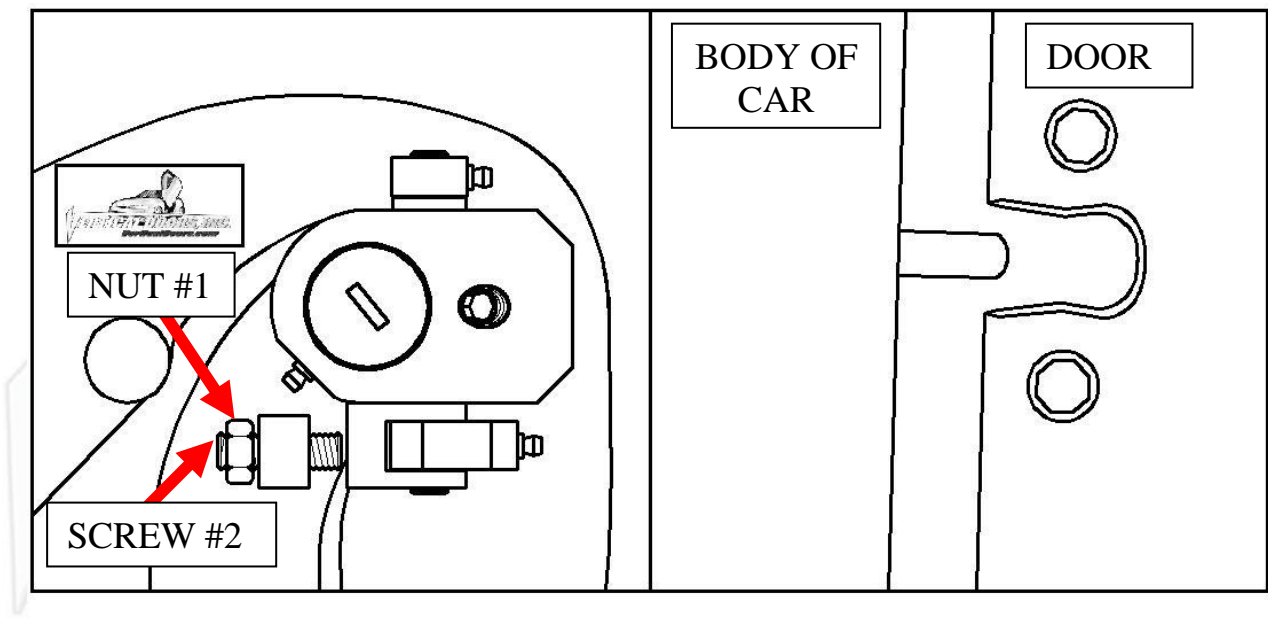

Note: You may need to slide the hinge forward or backward to make the hinge close properly.

Once the door closes properly you may secure all the bolts.
Refer to vehicles manufacturer for tork specifications

Adjust door opening screw #3 clockwise until distance between nub and swing arm is enough so that the swing arm moves up and down freely.

Hint (Fine tune the Allen Adjustment screw (#2) to realigned striker with door. After the door is align test door by opening and closing, lifting and lowering door several times.*

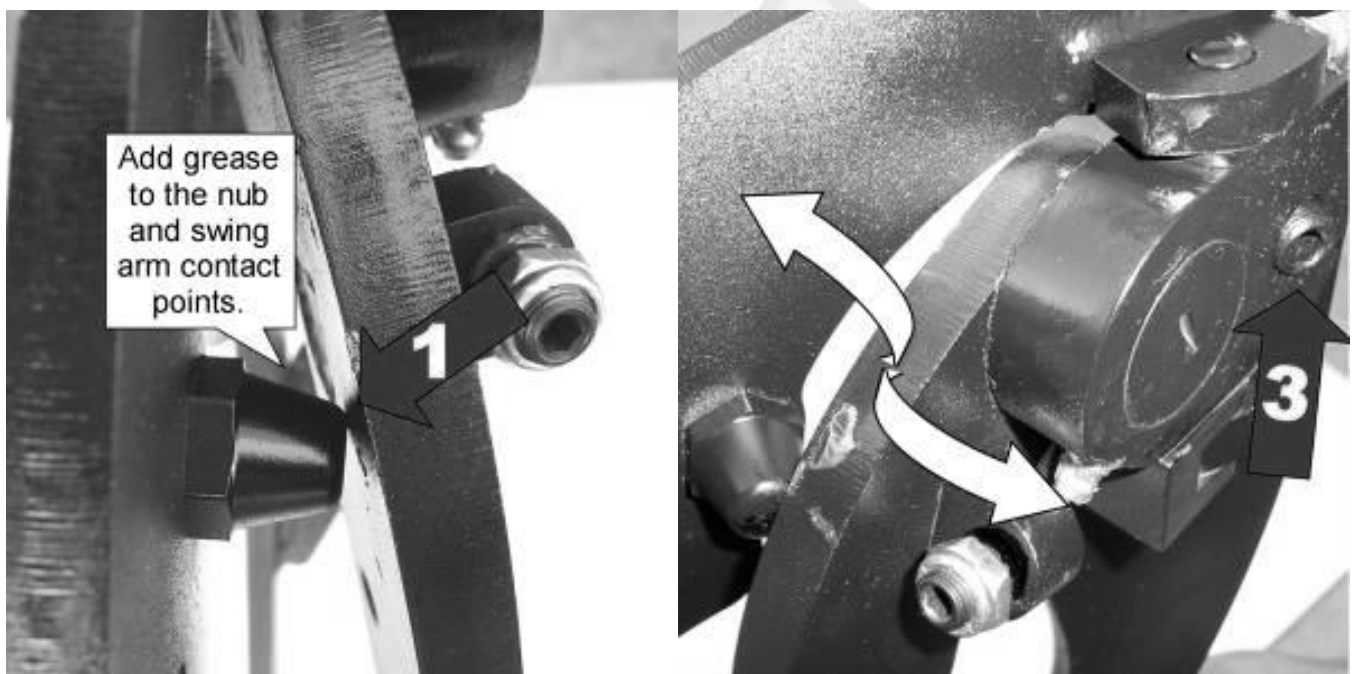

Re-install the splash guard starting at the front of the car.



You will need to use a heat gun as shown to mold the splash guard to the back of the hinge.



You will need to remove door catch by removing the door panel.
Remove the bolts on the front and bottom edge.
Usually there are 5 bolts total.



You will need to remove the bolts by the door handle to release the door panel



VERTICAL DOORS, INC.
VerticalDoors.com



VERTICAL DOORS, INC.
VerticalDoors.com

Thank you for your purchase of the
VERTICAL DOORS INC. SYSTEM

Simply Uplifting



NOTE:

Vertical Doors Inc. assumes no responsibility for any damages caused by improper installation